

PROGNOSTIC HEALTH MANAGEMENT (PHM) SOLUTIONS FOR BATTERY PACKS USED IN CRITICAL APPLICATIONS

John Bush, James Hofmeister, and Sonia Vohnout

Ridgetop Group, Inc.

6595 N. Oracle Rd.

Tucson, AZ 85704

Telephone: (520) 742-3300

John.Bush@RidgetopGroup.com

James.Hofmeister@RidgetopGroup.com

Sonia.Vohnout@RidgetopGroup.com

Abstract: Nickel-cadmium (NiCad) battery packs are absolutely necessary for providing mobile power sources in the modern-day Navy. Because the individual cells that comprise a battery only provide small voltage levels (typically 1.2 V), the cells are connected in series to add up and provide the necessary voltage. This cell stacking process, however, presents problems in monitoring, charging, and discharging. The primary reliability problem with battery packs can be traced to differences in the individual cells comprising the battery. Since there are inevitable differences in the cells, a low-capacity cell can become reverse-charged as the battery pack is put under load conditions. This reverse charge greatly reduces the lifetime of the cell. Likewise, another cell can become over-charged during a battery pack charge if the battery pack's total voltage is the sole monitoring criteria for determining when to stop the charge process. The problem worsens through repeated charge/discharge cycles. Normally, only the aggregate overall voltage of the battery pack is measured, but the individual degraded cell is not isolated. In that case, no anomaly may be detected, but usage time can be greatly diminished. To avoid this problem, battery packs are routinely replaced even though they don't exhibit any problems. This is a very costly procedure and decreases operational readiness of the battery-powered equipment. This paper presents a solution that will allow remote monitoring of a battery pack in the equipment without removal from service. It could also be connected to a larger prognostic and health monitoring (PHM) or Condition-based Maintenance (CBM) system. In addition, the solution will improve the charging efficiency, extend the useful life, and increase overall capacity of rechargeable NiCad battery packs through a principle known as cell balancing.

Among a stack of NiCad cells, each battery will be slightly different in its State-of-Charge (SOC) and Capacity-to-Energy (C/E) mismatch. Under conventional charging methods, all cells are charged (and discharged) at the same current, and the battery pack is limited by its weakest cell. However, the design presented is capable of measuring the individual cell voltages of a 20-cell series-connected battery pack. This system will consist of an Intelligent Control Module ASIC, a multi-tap transformer, and solid state switches to allow any cell in a 20-cell series-connected battery pack to be monitored, balanced, and charged/discharged. Although the design discussed will be for a 20-cell battery pack, it can easily be modified to other cell lengths.

Key words: Diagnostics; prognostics; health management; battery; NiCad; battery pack; remaining useful life

Background: This paper describes an innovative solution that will improve the dependability and reliability of a NiCad battery system through monitoring and balancing the state of charge of each individual cell in a series-connected battery pack. This innovation significantly reduces maintenance and unnecessary battery pack replacement costs for critical military applications. The described application-specific integrated circuit (ASIC) solution provides important prognostic, usage, and life-time feedback to user and maintenance personnel.

The primary reliability problem with battery packs can be traced to differences in the individual cells comprising the battery pack. Normally, only the aggregate overall voltage of the battery pack is measured, but the individual degraded cell is not isolated. In that case, no anomaly may be detected, but usage time can be greatly diminished. To avoid this problem, battery packs are routinely replaced even though they don't exhibit any problems. This is a costly procedure and decreases operational readiness of the battery-powered equipment.

The U.S. military uses a great number of series-connected NiCad battery systems, and monitoring the health and predicting the lifetime of these battery packs has been difficult. For many systems that utilize these battery packs, such as the H-60 helicopter sonar system, replacement and charging is difficult and costly. Because the individual cells that comprise a battery only provide small voltage levels (typically 1.2 V), the cells are connected in series to add up and provide the necessary voltage. This cell stacking process, however, presents problems in monitoring, charging, and discharging. Since there are inevitable differences in the cells, a low-capacity cell can become reverse-charged as the battery pack is put under load conditions. This reverse charge greatly reduces the lifetime of the cell [1]. Likewise, another cell can become over-charged during a battery pack charge if the battery pack's total voltage is the sole monitoring criteria for determining when to stop the charge process. The problem worsens through repeated charge/discharge cycles.

This research presented in this paper was sponsored by the U.S. Navy SBIR Program. The Navy is looking at reducing costs and improving the reliability of the NiCad battery packs of the MH-60R Sonar System. The current cost to replace the NiCad battery packs for the MH-60R Sonar System is almost \$500,000 and is a lengthy four- to six-month process during which the asset is unavailable for use. [2]

Series-connected batteries are becoming much more pervasive as the desire for portability becomes more acute. Typical applications today are in laptop computers, hybrid automobiles, satellites, and portable electronics. In hybrid automobile systems, a great number of individual rechargeable batteries are connected in series to produce a voltage high enough to power the electric motors used in these vehicles. As is the case in any battery system of this type, individual cell balancing is critical for long life and

reliability. The solution presented will allow remote monitoring of the battery pack in the equipment without removal from service could be connected to a larger prognostic and health monitoring (PHM) or Condition-based Maintenance (CBM) system.

Current Level of Technology: Typically, a charge current is fed into the battery pack for a specified period of time and then the overall battery pack voltage is measured. If the pack is brought up to its specified voltage level, the charger then goes into a current trickle mode which is meant to maintain the pack voltage. The main problem with the current methodology is that there are intrinsic differences in the individual cells of the battery pack and they age differently over time. Therefore, a weak cell may be pushed into an under voltage condition during discharge, which will shorten its lifetime and exacerbate the problem.[3] [4]

A secondary problem with the current technology is that a strong battery may be pushed into an over-charge condition. This too shortens its lifetime. In an over-charge condition, (1) excess hydrogen can be produced which can cause the cell to rupture (2) excess oxygen can be created and recombining it at the cathode generates heat which can cause the separator and seals to weaken and lead to early failure of the battery pack.

Another limitation with the current technology is fault isolation. Current methods cannot identify a weak or faulty cell within the battery pack. NiCad batteries are susceptible to an electrochemical condition called memory effect, where the battery “remembers” the prior decreased voltage level it had on it but its energy producing capacity is greatly reduced. If the voltage of the battery pack is measured, it appears as though the pack is completely charged, however the current supply capability and therefore the “run-time” is greatly reduced.

A Battery Pack Monitoring System: The monitoring system described in this paper will improve the charging efficiency, extend the useful life, and increase overall capacity of rechargeable NiCad battery packs through a principle known as cell balancing. Among a stack of NiCad cells, each battery will be slightly different in its State-of-Charge (SOC) and Capacity-to-Energy (C/E) mismatch. Under conventional charging methods, all cells are charged (and discharged) at the same current, and the battery pack is limited by its weakest cell. However, the design presented is capable of measuring the individual cell voltages of a 20-cell series-connected battery pack. This system will consist of an Intelligent Control Module ASIC, a multi-tap transformer, and solid state switches to allow any cell in a 20-cell series-connected battery pack to be monitored, balanced, and charged/discharged. A top-level architecture of the battery pack management system is shown in

Figure 1. Although the design for this effort will be for a 20-cell battery pack, it can easily be modified to other cell lengths.

In this example, battery 2 is undercharged and receives recharging, but the other batteries do not receive it, since they have been measured to be fully charged. The amount of charge is determined via a microcontroller with a built-in analog-to-digital converter to measure the voltages in a sense line. If the voltage measurements warrant recharging,

then the duty cycle is correspondingly adjusted. With this advanced battery management system, the individual batteries are measured for their voltages, and directed amounts of recharging. The battery management system includes a microcontroller and a transformer subsystem.

The key to this method of monitoring the performance and mitigating voltage problems is to precisely monitor the voltage from the individual cells and monitor the charge and discharge rates. Through the use of this innovative solution, the usage and reliability of the battery pack can be maximized. While commercial IC vendors offer limited functionality the solution being presented with the use of a transformer supports monitoring, balancing and charging in one compact assembly.

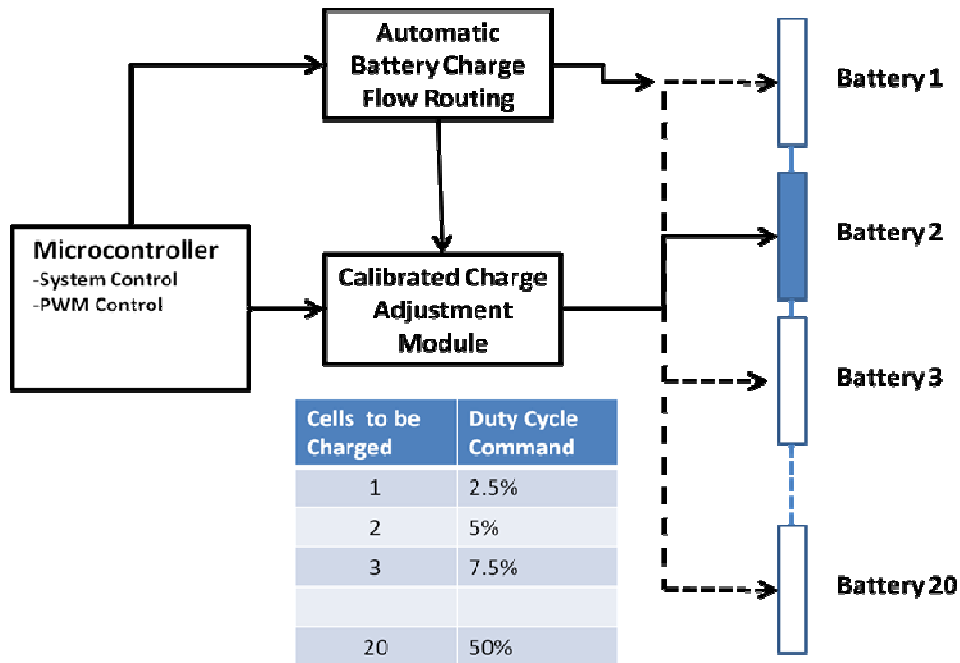

Figure 1: Top-level architecture of a battery management system

Microcontroller and Associated Firmware: The system is under the automated control of a Texas Instruments Stellaris Microcontroller. This subsystem is responsible for controlling the regular monitoring of the battery voltages, and precisely recharging the battery or batteries as calculated through its firmware. In the field, NiCad batteries will degrade at varying rates, and the ability to precisely monitor and recharge them is required. With the proposed system, there is a fixed, out-of-band clock frequency output that varies in its duty cycle to meet the charging requirements. Low recharge requirements require a low duty cycle, while high charging requires a higher duty cycle. This variable duty cycle output, from minimum levels to maximum, drives the transformer subsystem section.

The Transformer Subsystem: The target Navy battery system, employs battery pack charging through applying a voltage across the top and bottom end of the 20-battery,

series-connected string. The current approach does not allow for segregation of bad or degraded batteries within the 20-battery string.

The principle of operation for the transformer in Ridgetop's solution is shown in Figure 2, which depicts the basic elements from the flyback converter. In this simplified diagram, the control circuitry is omitted, and the switching MOSFET is represented by an ideal switch, T1. Diode D is implemented using a power MOSFET biased as a synchronous rectifier.

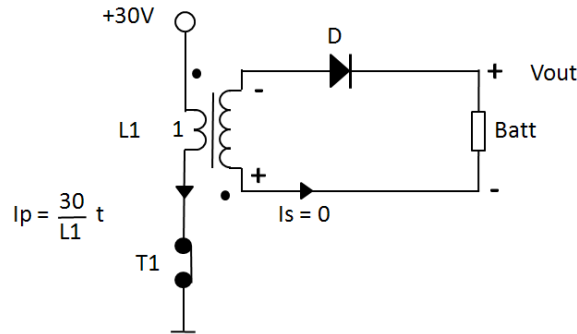

Figure 2: Phase one, storing energy in the transformer

The primary side of the transformer is solely an inductor. As a result, the primary current will increase linearly. To produce secondary current, the switch will be commanded to open (Figure 3). The current that was flowing through the primary winding at the moment just before the switch was opened is I_{peak} .

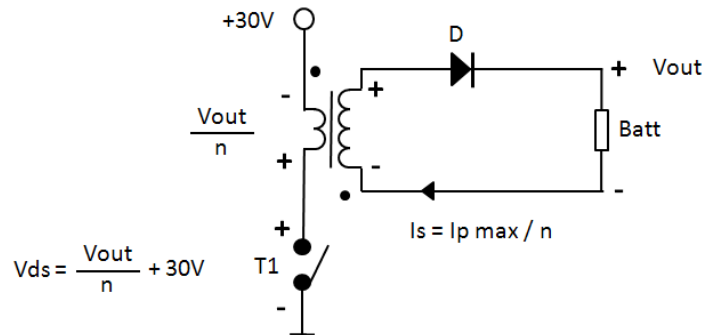

Figure 3: Phase two, dumping the energy from the transformer into the battery

The main advantage of a flyback converter over a forward converter is that the diode at the secondary side only has to block a high voltage while the current is low (I_{peak}/n), whereas the switch (MOSFET) in the forward converter has to carry a large current during the on phase and a high voltage during the off phase. In the flyback converter the voltage during the off phase is transformed down to a value determined by the transformer turns ratio. This results in reduced losses and increased efficiency.

This energy transfer continues until all energy stored in the secondary side of the transformer is dumped into the battery. At that moment the voltage induced at the primary side (V_{out}/n) will vanish. However, the parasitic capacitance of the switch (source-drain capacitance of the MOSFET) will be charged to $(V_{out}/n)+30$ V.

No transformer is ideal and there will be magnetic field lines generated by the primary windings which are not fully enclosed by the secondary windings. This will cause a stray inductance that can be modeled as a small inductor in series with the primary winding of the transformer (Figure 4). At the primary side now a series resonant tank circuit is formed with a charged capacitor where L_{stray} represents lossy portion of the flyback transformer.

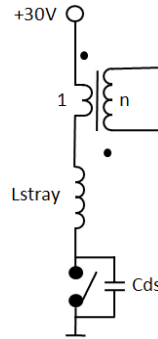

Figure 4: The stray inductance is modeled in the primary of the flyback

A novel aspect of the design is the extension that provides for the use of a multi-tap transformer to charge, balance and monitor each cell contained within the 20-battery string configuration. The reasons for selecting this approach include:

- The transformer secondaries allow full isolation of each cell, and no large common mode voltage issues will arise.
- The charging is done using a flyback mode where the adjustment of voltage is controlled through precise duty-cycle adjustment of the clock.
- Discharging is done through the transformer. This puts difficult constraints on the design and specification of the transformer.

To charge the batteries, a flyback configuration is used, but to read the voltage and to balance the batteries, a forward configuration is used. In the forward mode, the transformer acts as a normal transformer not as a coupled inductor as in the flyback mode. The output voltage is instantly “transformed” across the windings and its amplitude is based on the turns ratio of the windings.

The design of the transformer concentrated on the charging aspect since it would be one of the limiting factors in the design.

Some of the design specifications for the transformer were:

- Min. 30 VDC input voltage
- Ability to charge 20 batteries at a 1C rate (approx. 1 A) – 24 V at 0.958 A (23 W)
- Approximate a constant current charging method

The peak current in the primary side of the transformer can be calculated as:

$$I_{PK} = \frac{2 \times P_{out}}{V_{in} \times D_{Max}} = 3 \text{ amps}$$

Where $P_{out}=23$ W is the power output desired, $V_{in}=30$ V is the input voltage and $D_{max}=0.5$ is the duty cycle.

The theoretical primary inductance is calculated from the following formula:

$$L = V_{in} \frac{\Delta t}{\Delta i} = 50 \mu\text{H}$$

From the manufacturer's data tables, the transformer specification for the flyback converter was developed and a part selected. Since this is a flyback transformer an air gap is required and the gap is calculated to be 0.58 mm.

The transformer design is used both as a flyback (to charge the batteries) and as a forward converter (to read the battery voltages). The transformer is designed using a standard set of equations based on the frequency of operation, estimated efficiency, input voltage, and desired output power. From these, the primary inductance is calculated:

$$L = \frac{0.4\pi\mu N^2 A_e \times 10^{-8}}{l_e} = 35 \mu\text{H}$$

where $\mu=91$, $N=12$, $A_e = 1.18$, $l_e = 5.55$.

Since the inductance is slightly less than targeted, the pulse width can be adjusted to compensate for this.

$$\Delta t = \frac{L}{V} \Delta i = 3.5 \mu\text{s}$$

This would increase the frequency from 100 kHz to 143 kHz. However, these numbers do not have to be exact since a microprocessor is in the feedback loop and will control the actual pulse widths. This only indicates the minimum frequency needed to charge the batteries at the 1C rate.

Simulation and Analysis of the Transformer Subsystem: Conventional Spice-like circuit simulation of the transformer in the flyback mode is difficult because of the discontinuous nature of operation, so lab bench verification was used. The forward direction simulations that were completed illustrate the behavior of the transformer operating in the forward direction. The simulation results indicate that, although there is noise in the system since switches are connected to the transformer, the battery voltages can be read as planned. A delay time will be inserted to allow the transients to die out or a snubber circuit to absorb this energy will be completed in the Phase II program. Schottky diodes will also be placed strategically across the windings to truncate the transients.

A breadboard of the circuit using this transformer was also built. The transformer is shown on the breadboard in Figure 5.

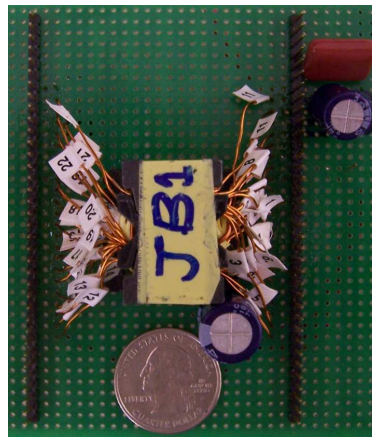

Figure 5: Breadboard of the circuit using the transformer (quarter included for scale)

Figure 6 shows the results of a simulation in the forward mode. The first part of the simulation is where the battery voltage is read and the rest of the simulation shows the noise that can be generated when switches are opened and closed when connected to the transformer. Steps were taken to minimize this noise, such as adding diodes, but all of the noise can't be removed. The noise, however, dies out fairly quickly and elimination is considered manageable.

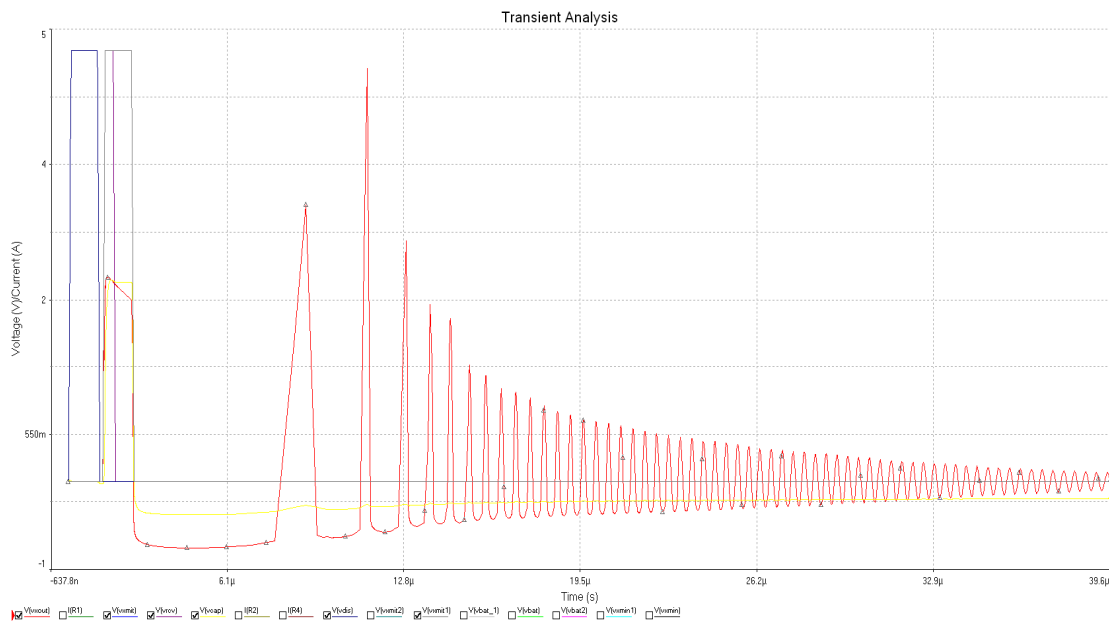

Figure 6: Simulation showing ringing of the transformer when switches are cycled

This simulation demonstrated the feasibility of the approach. The accuracy with which we can measure voltages will be explored with development of the demonstration unit.

The design functioned as designed, as can be seen by the waveforms shown in Figure 7.

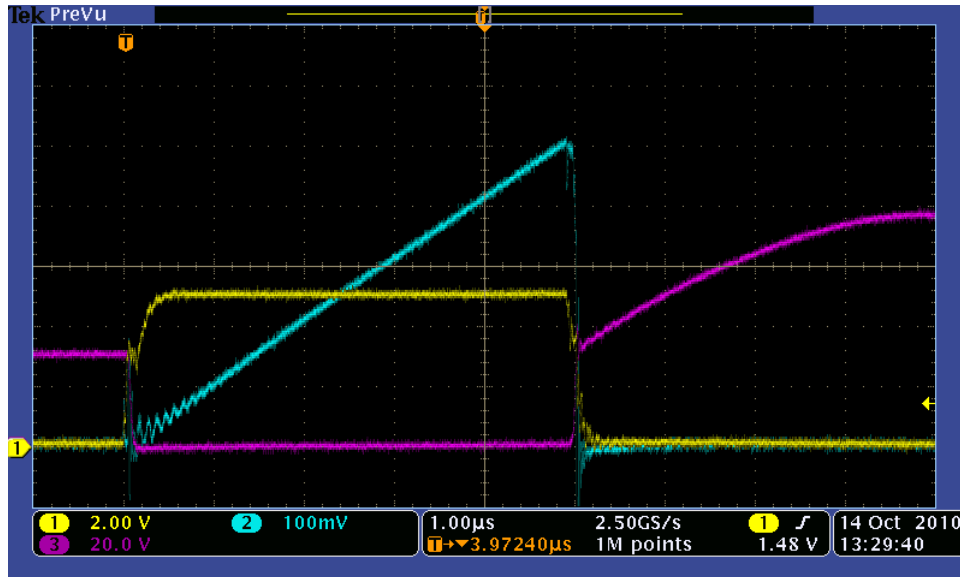

Figure 7: Oscilloscope waveform of the primary current (blue) and the primary voltage (magenta)

The yellow trace is the gate drive for the transistor switch in the primary side of the flyback converter. It is on (high) for 5 μ s. The blue trace is the current ramping up in the primary winding. It goes from 0 V to 500 mV, which is the voltage across a 167 Ω resistor, so the current is going from 0 to 3 amps, as designed. The magenta trace shows the inverse of the voltage across the primary winding. It starts at 30 V (or 0 V) and goes to 0 V (30 V), which is the main input voltage to the system. The next picture (Figure 8) is an expanded view and shows the no-load voltage in the secondary (green trace) in addition to the other traces.

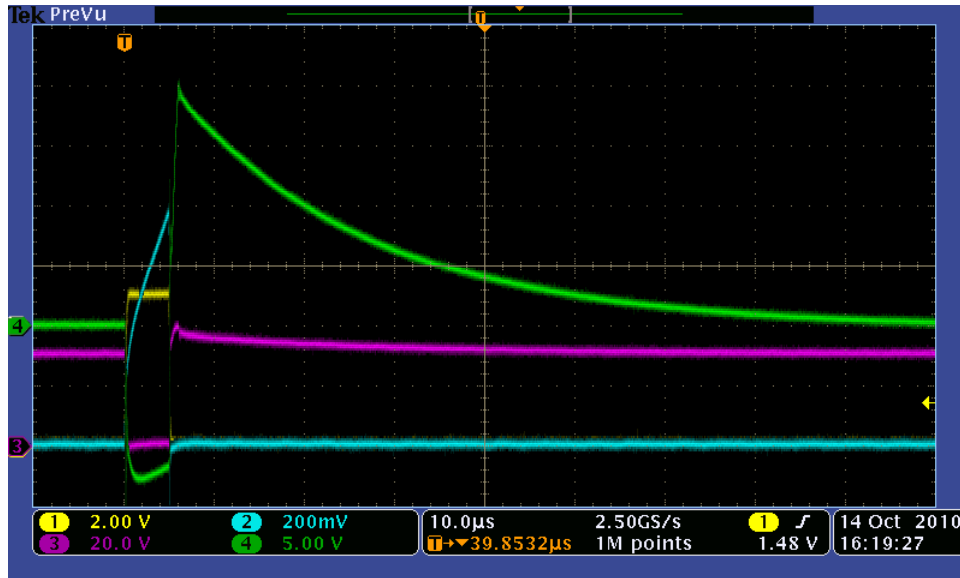

Figure 8: Expanded view of waveform in Figure 7, showing the no-load voltage in the secondary (green) trace in addition to the other traces

Control Subsystem Design: The design of the control block subsystem was finalized. The block diagram is shown in Figure 9. The control subsystem is made up of the controller and the switch decode.

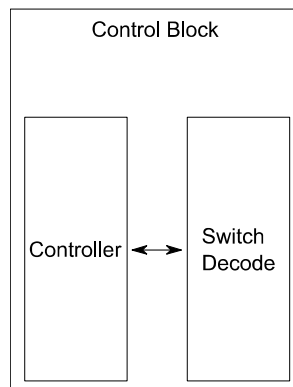

Figure 9: Block diagram of the control block subsystem

The 3-amp peak primary current is for charging the entire battery stack at the 1C rate in one hour. This can be increased up to the 4C or 5C rate to charge the batteries faster. Since this is a flyback charger, the energy put into the primary in the first half of the cycle determines the energy that is used to charge the batteries in the second half of the cycle. So if only one battery needs to be charged, then the controller decreases the pulse width to put out the appropriate charge for only one battery.

During the system setup, the controller checks for proper voltages and calibrates itself. Then it reads every individual battery to assess the system status. If it determines there is a bad battery in the system it goes to the bad battery routine. If there are weak batteries it charges those batteries to balance the system so all batteries can be charges equally.

To charge a weak battery or a couple of weak batteries at once, it decreases the pulse width to the appropriate level so the correct amount of charge is put into the primary of the transformer and only closes the switches to those batteries needing charge. After an appropriate amount of charge time, the battery voltages are read and if all are balanced, the entire stack of batteries are charged together. After an appropriate charge time, the system reads all of the battery voltages again to evaluate whether the batteries are fully charged.

There are several ways to determine if the batteries are fully charged. One method is to read the temperature of the batteries. The batteries will heat up as they are charged. Then, after full charge, the temperature will begin to decrease. Although many systems use this method, it is far from ideal. Some of the problems are:

- Uneven temperature due to different charge levels
- Ambient temperature effects
- Delay in evaluating the temperature peak since the entire mass has to come up to temperature
- Where to place the thermocouple – do you use multiple ones?

The delay in measuring the peak temperature means that the batteries become overcharged which will reduce their lifetime.

A better way to read the fully charged state is by tracking the voltage on the individual batteries. The voltage will increase as the batteries charge. When the batteries are fully charged and more charge is added, the voltage will start to decrease. Since our approach allows each battery voltage to be read and that data can be saved, we can accurately determine the fully charged state without overly charging the batteries. A temperature sensor with 0.1 °C resolution will be included and used as a “fail-safe” monitor to ensure that the operating temperature does not exceed the operating limits and cause a fire.

Degradation Analysis of NiCad Batteries: Twenty four commercially available NiCad batteries from a leading manufacturer (Tenergy) that are very similar to those currently being used in the NAVAIR system were procured. Several of these batteries were tested on an automated test system, shown in Figure 10.

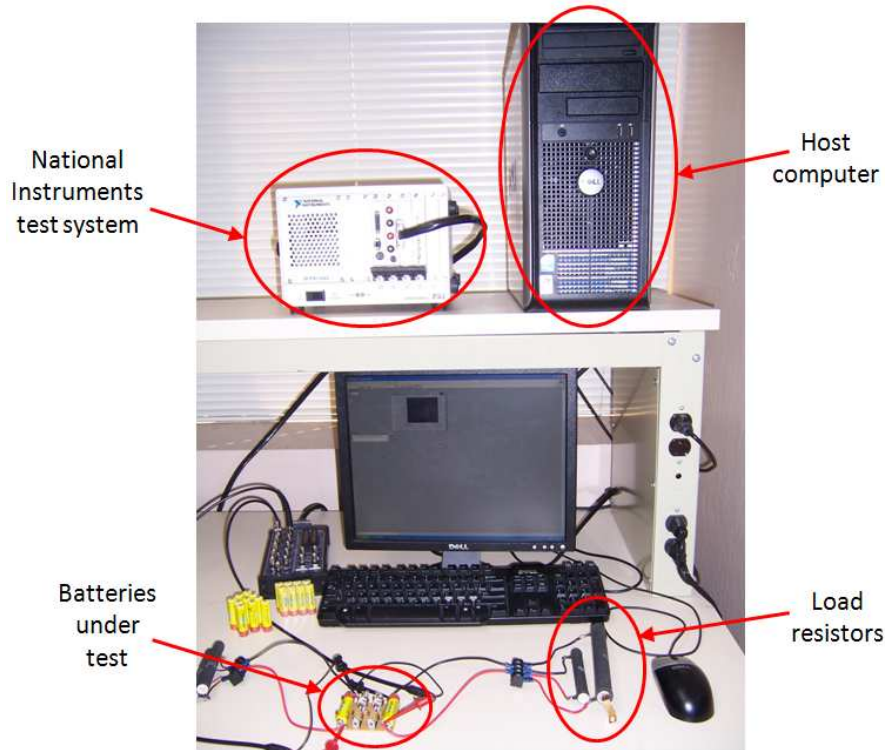

Figure 10: LabVIEW automated test setup

In this test procedure, fully charged batteries were discharged with a known load. Results of the test are shown in the chart in Figure 11. Battery B11 had a 1Ω load on it and battery B10 had a 10Ω load. The new batteries were charged and then put on load and discharged. Typically, with a heavy load such as 1Ω , the battery is said to be discharged when the voltage reaches 1 volt, and with lighter loads, a voltage limit of 1.2 volts is used.

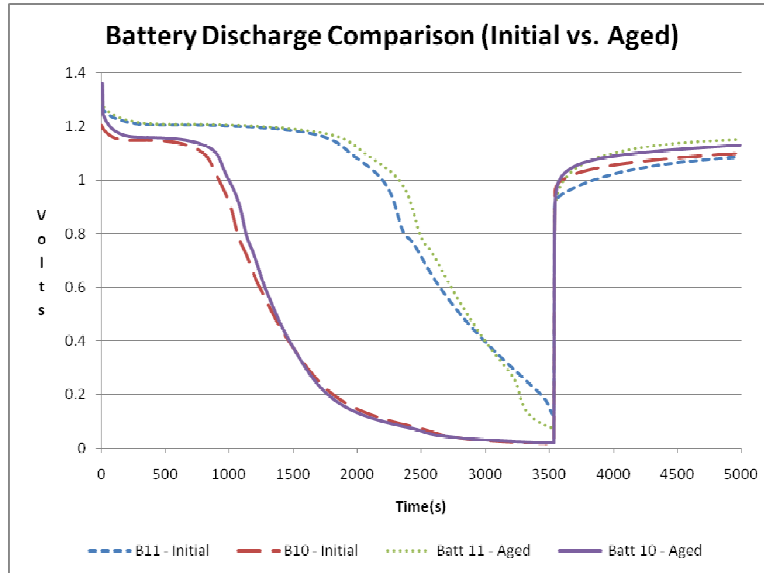

Figure 11: Battery discharge rates – B11 with a 1 Ω load and B10 with a 10 Ω load

An interesting point of this data is that the aged batteries actually perform better than the new battery. This is normal. Typically, the dielectrics in new batteries are not fully formed until a few dozen uses so the capacity will increase to that point and then begin to decline.

Conclusion and future developments: The state of charge (SoC) of the battery indicates how much charge is left in the battery to give an estimate of remaining runtime left in the battery. Some systems do that now by measuring the open circuit voltage on the battery and estimating the state of charge by that voltage. This is problematic, since the discharge voltage curve is very flat for most of the discharge cycle, leading to inaccuracies. In our system, we apply a known load to the battery and are able to read the voltage. This leads to a much more accurate reading. In future phases, an advanced algorithm to provide accurate results will be developed. This will entail studying the discharge curves and determining what the ideal load is and how to read it accurately.

The remaining useful life (RUL) of a battery is an indication of how many more charge/discharge cycles a battery can go through before it is at its end of life. This indicator is very useful in determining when preventive maintenance should be performed and when batteries should be replaced. This offers a huge cost savings for the end user of the equipment by allowing them to schedule maintenance and allowing the equipment to be “available for use” for a greater period of time. The end user can then assess the probability that a particular piece of equipment can successfully complete a mission.

During the next phase of this research, we will undertake a study that will quantify the increase in lifetime. We will acquire a significant sample of batteries from various manufacturers and put them on an extended lifetime testing regime where they will be run through charge/discharge cycles until failure.

Although we focused only on nickel-cadmium (NiCad) type batteries, this technology could be applied to nickel metal hydride (NiMH) and lithium ion (Li-Ion) type batteries as well, and therefore this technology would be very useful in an upgraded system or in other DoD equipment.

References:

- [1] Intersil (P/N AN1333) - Designing Multi-Cell Battery Packs Using the ISL9208 Analog Front End
- [2] "MH-60R Sonar NiCad Battery Reliability Improvement ".Navy SBIR 2010.1 - Topic N101-018, http://www.navysbir.com/n10_1/N101-018.htm
- [3] "NiCad Battery Apps. Manual," Eveready Battery Co, 6 Nov. 2001, 18 April 2009; http://data.energizer.com/PDFs/nickelcadmium_appman.pdf
- [4] Simpson, Chester. "Battery Charging," National Semiconductor 1995, 18 April 2009; <http://www.national.com/appinfo/power/files/f7.pdf>

Bibliography:

[1] **John Bush** has over 30 years experience in the semiconductor industry. He has worked as an IC design engineer and applications engineer/manager for Texas Instruments, NCR Corp., Motorola/Freescale, and presently with Ridgetop Group. He is co-holder of two U.S. patents with two more pending. His technical interests are analog and digital design. He received a BSEE from the University of Kansas in 1976.

[2] **James Hofmeister** is a senior principal engineer and engineering manager. He has been a software developer, designer and architect for IBM and represented IBM as a member of the board of directors of the Southern Arizona Center for Software Excellence. At Ridgetop Group, he is a principal investigator and lead design engineer, specializing in analog and digital circuit designs for electronic prognostics. He is a co-author on six U.S. patents (3 IBM and 3 Ridgetop), two other pending Ridgetop patents, and four recent invention disclosures. He retired from IBM in 1998 after a 30-year career and joined Ridgetop Group in 2003. He received a BS in electrical engineering from the University of Hawai'i, Manoa Campus, and a MS in electrical and computer engineering from the University of Arizona.

[3] **Sonia Vohnout** earned her MS in Systems Engineering from the University of Arizona in Tucson. With a diverse background and experience, Sonia is well-suited to manage Ridgetop's commercialization efforts from its many government-funded projects. Sonia joined Ridgetop after successfully building an electronic subassembly business in Mexico, working as a Systems Engineer at IBM and handling overseas installations of software with Modular Mining Systems (now part of Komatsu). During her career, she has held executive management and senior technical positions. In addition, Sonia has co-founded several companies. Sonia is a board member of the Society for Machinery Failure Prevention Technology (MFPT) (www.mfpt.org), an interdisciplinary technical organization strongly oriented toward practical applications. Sonia recently founded the Prognostic and Health Management (PHM) Professionals LinkedIn Group (www.linkedin.com), a fast growing group whose objectives are to: Discuss PHM related topics, network with others in the PHM community, and increase awareness of PHM.